

FOMAX®











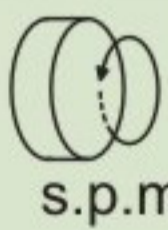

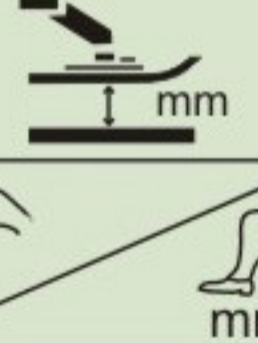
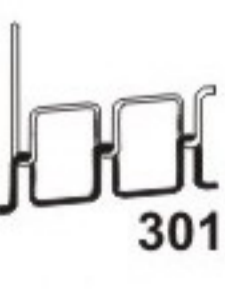
KDD-5572 / KDD-5573

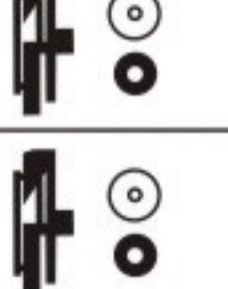
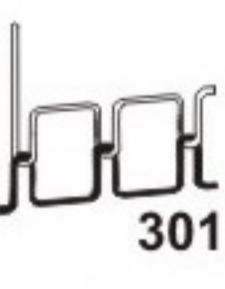
Máquinas de pespunte de 1 aguja de coser y cortar.
 KDD-5572: Arrastre normal por diente
 KDD-5573: Arrastre por aguja y diente.

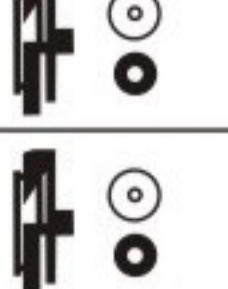
1 needle lockstitch sewing machine with edge cutter.
 KDD-5572: bottom feed
 KDD-5573: needle feed

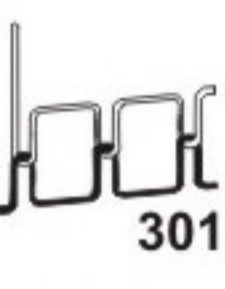
Machine à point noué, à coudre et couper.
 KDD-5572: entraînement par griffe
 KDD-5573: entraînement par griffe et aiguille

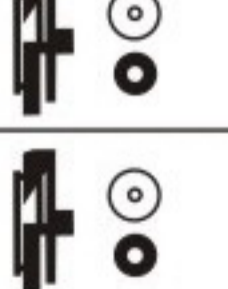

MODEL	Nº s.p.m.							ATTACHMENT	MAX. mm
KDD-5572	x1 5.500	DBx1: 1~16	4 / 10						4,5
KDD-5573	x1 5.000	DBx1: 11~14	4 / 10						4,5

Máquina de coser y cortar que proporciona una alta calidad de costura y de corte a 5.000 p.p.m. Equipadas con un mecanismo que impide que trozos de tejido recortado entren en el garfio. Equipadas con engrase automático.

Sewing with edge cutter machine which makes a high quality sewing and cutting at 5.000 s.p.m. Equipped with a special mechanism which prevents that fragments of fabric get into the hook. With automatic lubrication.

Machine à coudre et à couper qui rend une couture et une coupe de grande qualité a 5.000 p.p.m. Elle a un mécanisme qui empêche que les morceaux de tissu entrent dans le crochet. Avec lubrification automatique.