

FOMAX®









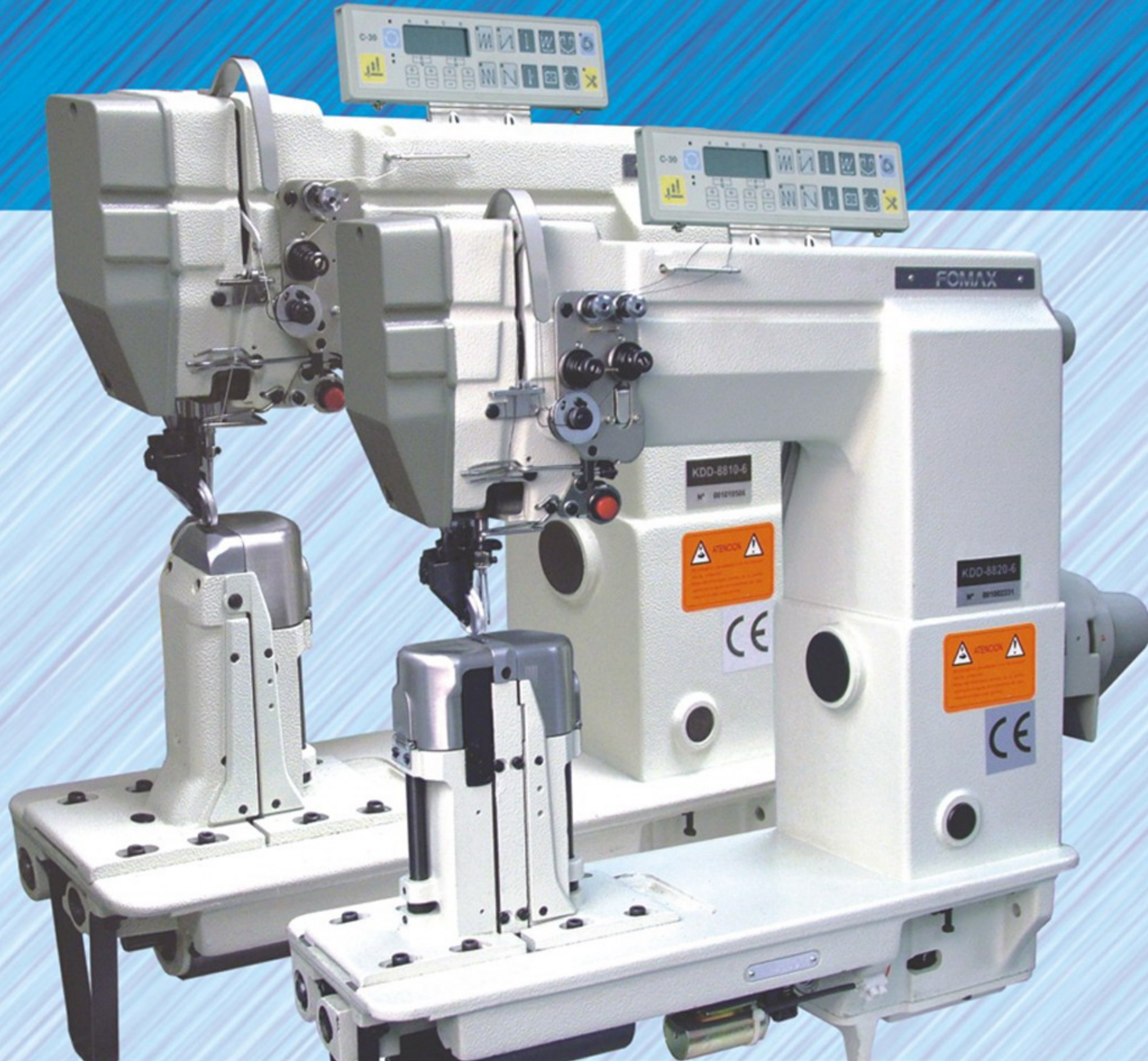

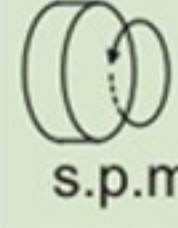

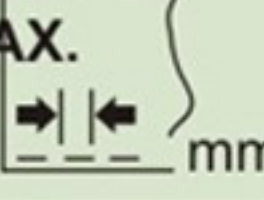

KDD-8810-6 / KDD-8820-6

Máquinas de columna de 1 y 2 agujas , arrastre sincronizado, con cortahilos eléctrico.

1 and 2 needles postbed sewing machine with electric trimmer, upper and lower driven Roller feed dog

1 oder 2 Nadel Nadeltransport- Säulenmaschine mit angetriebenem Rollfuss und Schiebradtransport.



MODEL	Nº	 s.p.m.		 mm				ATTACHMENT	MAX.  mm
KDD-8810-6	x1	3.000	DPx5:11~14	 mm					7
KDD-8820-6	x2	3.000	DPx5:11~14	7 / 14	301				4,8

Máquinas de columna de 1 y 2 agujas, arrastre sincronizado, aguja acompañante, con cortahilos eléctrico, sin atacado, para costura de artículos medios-gruesos de pequeño radio tales como zapatos de piel, bolsos de piel, etc..

1 and 2 needles postbed sewing machine with electric trimmer, upper and lower driven roller feed dog and presser foot, needle feed. For sewing medium-heavy articles with small radius like leather shoes, handbags, etc..

1 oder 2 Nadel Nadeltransport- Säulenmaschine mit angetriebenem Rollfuss und Schiebradtransport. Mit elektrischem Fadenabschneider, ohne Verriegelung.